



6565 Series Butt Weld Pipe Union, Class 6000

HART Industrial O-Ring Unions are engineered to provide Class 6000 Service and are the most popular union in the industry for general purpose applications. The flat face design provides turbulence-free fit across seats. This design is ideal where piping requirements dictate the necessity of having a flat face seal to make and break the pipe line. All HART Unions are made in the USA!

Schedule 80 wall thickness is standard, but any wall thickness is available (S160, XXH, etc).

Standard O-Ring Union Features:

- **Turbulence Free:** All unions provide a turbulence-free fit across the seats
- **O-Ring Isolation:** The O-Ring seal is strategically located in the thread piece face eliminating O-Ring media contact and added protection against abrasives and erosion. A variety of O-Rings for any application are available.
- **Precision Machined Components:** All unions are precision machined to provide high quality and fail-safe leak proof reliability.
- **Interchangeable End Connections:** Threaded (female and male), socket weld, and butt weld ends are interchangeable. This feature reduces overall costs by eliminating unnecessary nipples, bushings, couplings and inserts.
- **Material Versatility:** Unions can be provided in all standard metals or combination of metals. This includes 304 Stainless, 316 Stainless, A105 Carbon Steel, Brass, Monel 400, Hastalloy, and Titanium.
- **Excellent Vibration Resistance:** Seals will not loosen, even under extreme pressure and pressure surges.
- **No Maintenance:** Once initial seal is made, no further tightening required.

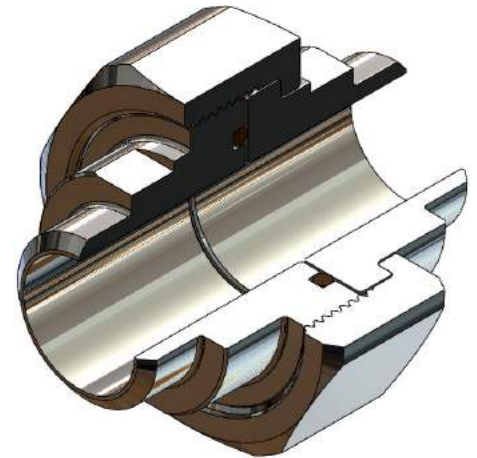

Union Dimensional Reference:

SIZE	A-NPS	B	C-HEX	D-FLATS	E-TAIL	F-THREAD	G-FLAT	WEIGHT (lbs)
6565-1	1/4"	2.90	1.82	1.13	1.41	1.49	1.00	0.70
6565-2	3/8"	2.90	1.82	1.13	1.41	1.49	1.00	0.70
6565-3	1/2"	2.98	2.15	1.38	1.45	1.53	1.15	1.00
6565-4	3/4"	3.01	2.50	1.75	1.45	1.56	1.50	1.75
6565-5	1"	3.24	3.06	2.16	1.62	1.63	1.88	2.50
6565-6	1-1/4"	3.14	3.38	2.38	1.54	1.60	2.13	3.50
6565-7	1-1/2"	3.47	3.88	2.88	1.64	1.83	2.56	4.25
6565-8	2"	3.59	5	3.61	1.78	1.81	3.25	6.00
6565-9	2-1/2"	3.65	5.75	4.3	1.84	1.81	4	8.00

NOTE: Dimensions are for reference only and are subject to change.

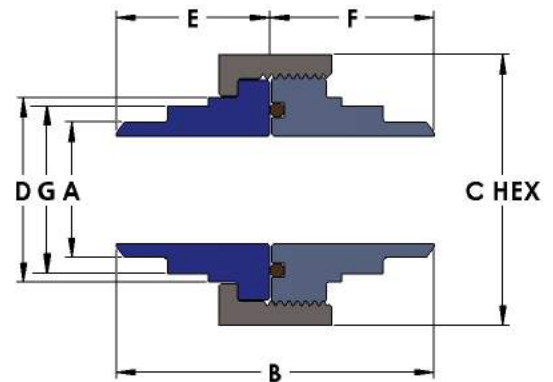

Questions? Call us at 1-800-769-0503. Our Customer Service and Engineering Teams are available to assist you with any needs!