

### 3434 Series Assembly Specifications

HART Size	A (Socketweld Tube OD)	B (Assembled)	C (Hex Nut Flats)	D (Body Diameter)	E (Tail)	F (Thread)	Weight
3434-1	1/4" TUBE	1.760	1.375	.750	.800	.960	0.330
3434-2	3/8" TUBE	2.005	1.815	1.125	.940	1.065	0.700
3434-3	1/2" TUBE	2.005	1.815	1.125	.940	1.065	0.700
3434-4	3/4" TUBE	2.155	2.145	1.375	1.030	1.125	1.000
3434-5	1" TUBE	2.600	2.500	1.750	1.250	1.350	1.750
3434-6	1 1/4" TUBE	2.770	3.062	2.160	1.380	1.390	2.500
3434-7	1 1/2" TUBE	3.105	3.375	2.375	1.530	1.575	3.500
3434-8	2" TUBE	3.280	3.875	2.875	1.550	1.730	4.250
3434-9	2 1/2" TUBE	4.010	5.000	3.610	1.990	2.020	6.000
3434-10	3" TUBE	4.280	5.750	4.300	2.140	2.140	8.000

\*UNLESS SPECIFIED OTHERWISE, ALL DIMENSIONS ARE IN INCHES\*

\*DIMENSIONS FOR REFERENCE ONLY AND ARE SUBJECT TO CHANGE WITHOUT NOTICE\*

\*ASSEMBLED LENGTH IS A COMPRESSED DIMENSION AND MAY VARY BASED ON O-RING COMPRESSION\*

\*DRAWING NOT TO SCALE\*

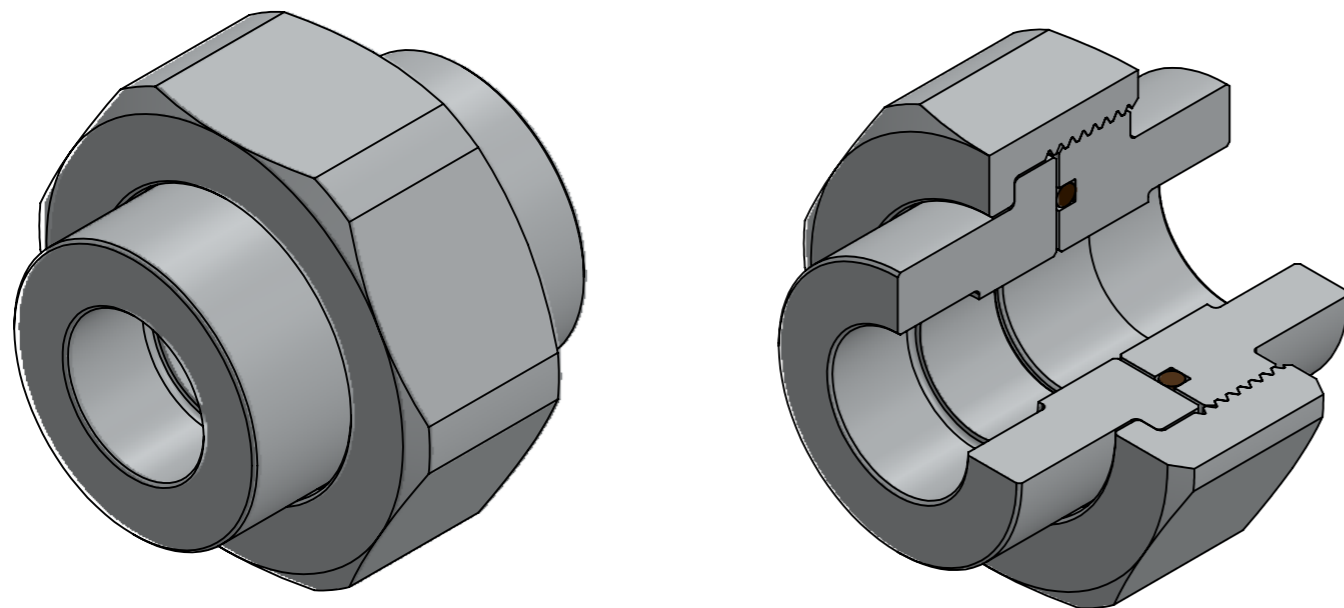

UNLESS SPECIFIED OTHERWISE, ALL DIMENSIONS ARE IN INCHES TOLERANCE: .XXX ± .005	DRAWN HWP	2-10-14	HART Industrial Unions, LLC P.O. Box 310429 Newington, CT 06131  <i>Sure Seal O-Ring Unions</i>
	CHECK SRT	2-10-14	
MATERIAL STAINLESS STEEL	REVISED BTC	2-23-23	TITLE: <b>3434 Series Assembly Specs</b>
COATING	CUSTOMER		ASSEMBLY 3434 Assembly
SCALE: NTS			A3 SHEET 1 OF 1