

3333 Series Assembly Specifications

HART Size	A (Socketweld NPS Size)	B (Assembled)	C (Hex Nut Flats)	D (Body Diameter)	E (Tail)	F (Thread)	Weight
3333-1	1/4" NPS	1.760	1.375	.750	.800	.960	0.330
3333-2	3/8" NPS	2.005	1.815	1.125	.940	1.065	0.700
3333-3	1/2" NPS	2.005	1.815	1.125	.940	1.065	0.700
3333-4	3/4" NPS	2.155	2.145	1.375	1.030	1.125	1.000
3333-5	1" NPS	2.600	2.500	1.750	1.250	1.350	1.750
3333-6	1 1/4" NPS	2.770	3.062	2.160	1.380	1.390	2.500
3333-7	1 1/2" NPS	3.105	3.375	2.375	1.530	1.575	3.500
3333-8	2" NPS	3.280	3.875	2.875	1.550	1.730	4.250
3333-9	2 1/2" NPS	4.010	5.000	3.610	2.020	1.990	6.000
3333-10	3" NPS	4.280	5.500	4.300	2.140	2.140	8.000

UNLESS SPECIFIED OTHERWISE, ALL DIMENSIONS ARE IN INCHES

DIMENSIONS FOR REFERENCE ONLY AND ARE SUBJECT TO CHANGE WITHOUT NOTICE

ASSEMBLED LENGTH IS A COMPRESSED DIMENSION AND MAY VARY BASED ON O-RING COMPRESSION

DRAWING NOT TO SCALE

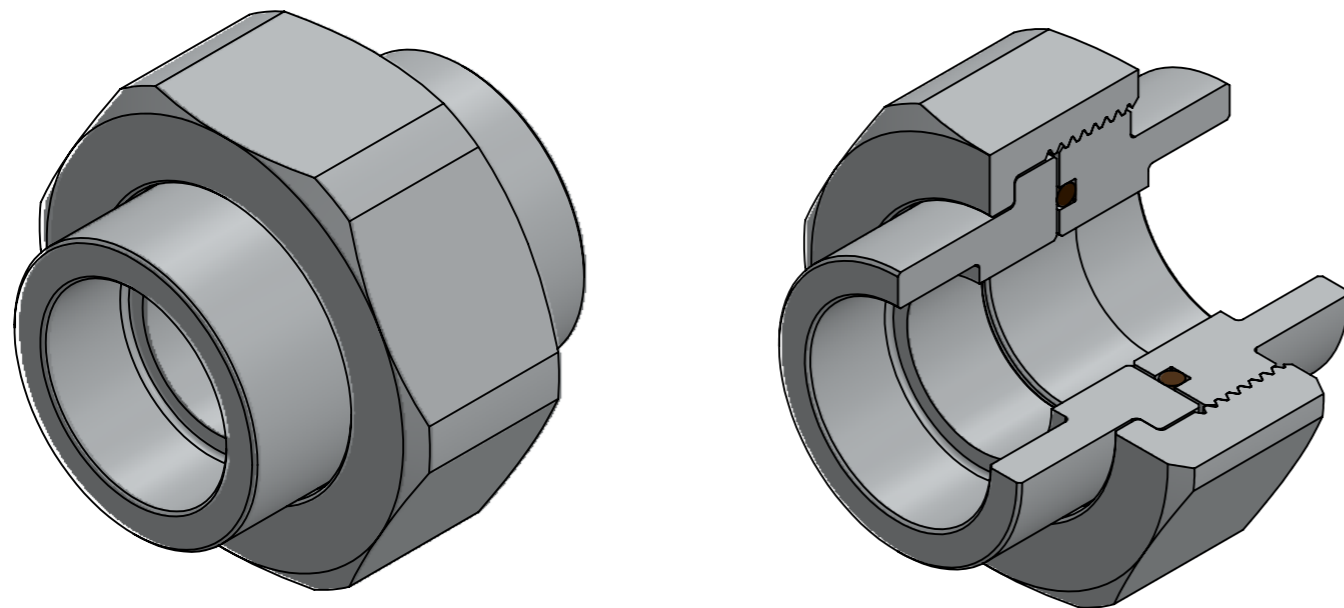

UNLESS SPECIFIED OTHERWISE, ALL DIMENSIONS ARE IN INCHES TOLERANCE: .XXX ± .005	DRAWN		HART Industrial Unions, LLC P.O. Box 310429 Newington, CT 06131	 Sure Seal O-Ring Unions
	HWP	2-10-14		
MATERIAL STAINLESS STEEL	CHECK		TITLE: 3333 Series Assembly Specs	
	SRT	2-10-14		
COATING	REVISD		ASSEMBLY 3333 Assembly	
	BTC	2-23-23		
	CUSTOMER		SCALE: NTS	